

Multifan



Tube Fans

Suitable for every tube, duct or chimney



VOSTERMANS
VENTILATION

YOUR SPECIALIST IN AIR

Multifan Tube Fans

A fan for every tube, duct or chimney

With the extensive line of standard Multifan Tube Fans, we offer a wide range of reliable and efficient fans. Do you need a customized size? No problem! We are able to deliver a customized fan between 250 mm and 963 mm. For applications where extra capacity and efficiency is demanded, we offer an extra-large 130 cm Tube Fan. Thanks to our flexible range, we are always able to offer the right fan solution for every ventilation need. Multifan Tube Fans are optional available with the energy efficient ECplus technology.



Why choose this fan?

- Able to offer customized fan sizes for your application
- Materials resistant to extreme corrosive environments
- Extreme durable fan with a long lifetime
- Easy installation and maintenance
- High performances and energy efficient
- 3-year warranty on the fan motor



Features

- For horizontally or vertically mounting (vertically for 130 cm Tube Fan)
- Suitable for ambient temperatures up to 40 °C
- Water and dust resistant fan motor (IP55)
- Low noise level
- Belt drive for 130 cm Tube Fan

Applications

- Agricultural: Pig, Poultry and Dairy
- Horticulture: Greenhouse
- Industry: Cooling, Heating and Ventilation

Optional available

- On request suitable for ambient temperatures up to 70 °C
- Tube mounting fastener set
- Energy saving ECplus technology
- Tube Fans for high pressure applications (up to 400 Pa)

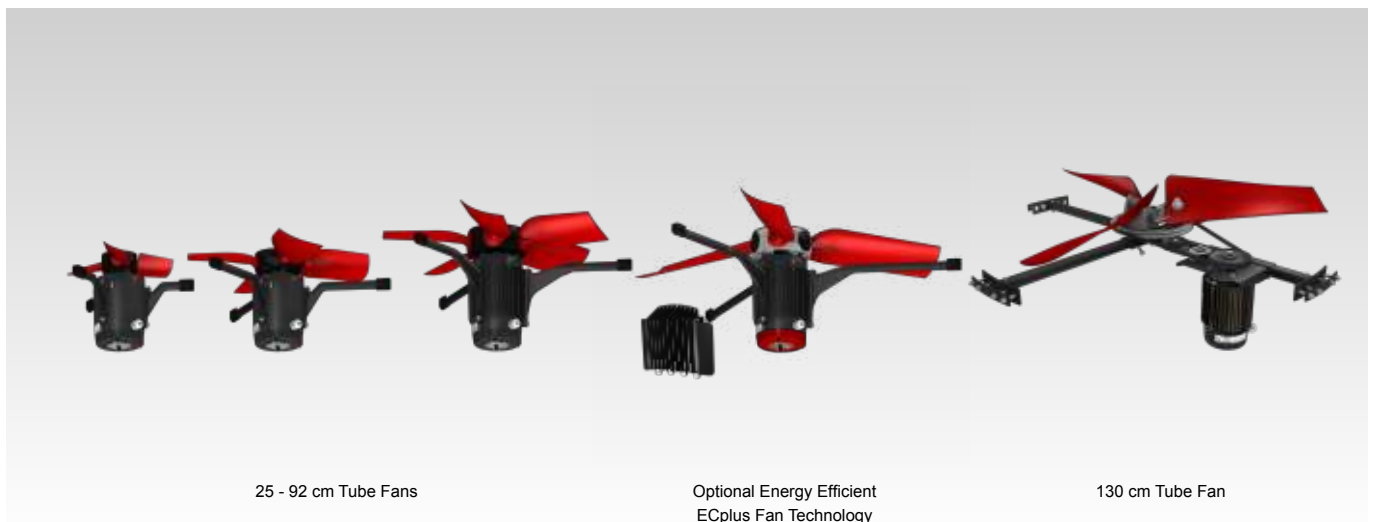



“We have installed the Multifan Tube Fans with the ECplus technology 6 months ago and washed it 3 times: no problems accrued, neither do we expect any, since it is waterproof. Multifan is very interesting for existing and new houses, we would buy again!”

John Tate, Tate Farm, Northern Ireland

Save more energy with our ECplus technology

With the ECplus technology we combine excellent performance and robust quality with high energy savings up to 80%. The stepless ECplus controller enables a smooth and precise ventilation system. We know the reliability of the fan is for most of our customers a key aspect. With the optional override switch your fan is secured for controller failures (for example by lightning).

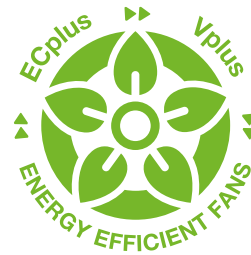

Why choose ECplus technology?

- Energy savings up to 80%
- Extreme energy efficient controller
- Quick return on investment

Features:

- Water and dust proof controller (IP67)
- LED indication for status codes
- Mounting brackets for easy installation (optional)



Examples of ECplus Fan technology applications
High Pressure Fan - Panel Fan - Tube Fan



Preferred setup

For optimal performance and controllability, we recommend a tube with an inlet flange and a minimum tip clearance of 5 mm.

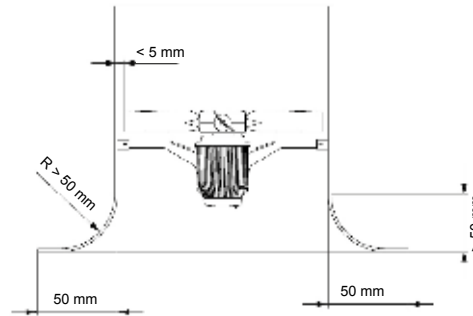

Dimensions

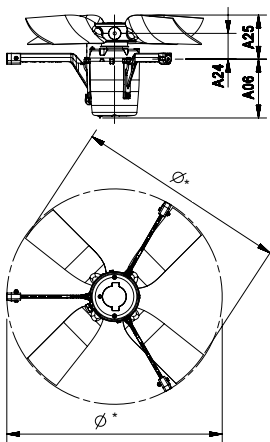

Figure 1

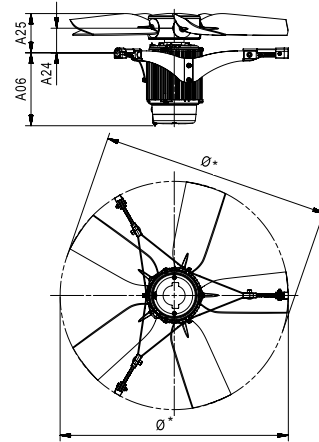

Figure 2

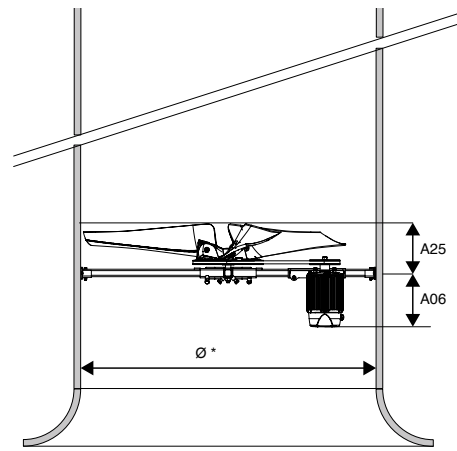

Figure 3

Diameter (cm) *	Figure	A06 (mm)	A24 (mm)	A25 (mm)	
25 - 50	1	170	74	Min. 105	Max. 127
50 - 92	1	221	82	Min. 128	Max. 137
63 - 71	2	227	76,5	Min. 122,5	Max. 131,5
130	3	235		210	

* Mounting supports and impellers are adjustable to your demand.